



**CORPORATION - LIMITED**



## **LINTECH CONVEYOR PULLEYS**

**ENDORSED TO:**  
**ISO9002-1999**  
**FOR THE MANUFACTURE OF**  
**CONVEYOR PULLEY**



## CONVEYOR PULLEY – MEDIUM-HEAVY-EXTRA HEAVY DUTY

### CUSTOM PRECISE DESIGN FOR EACH PULLEY

LinteCh treat each pulley as individual custom design, to identify the exact load on each pulley as a part of the complete conveyor system to ensure long life design of each pulley component.

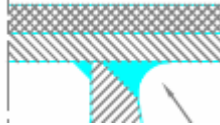

#### ENGINEERING PROGRAM

We research and update LinteCh engineering program to improve our product to meet the closest application conditions. Each Pulley loading data are inputted into program, specific for each project. Our Mechanical Engineers has high capability in designing and manufacturing the conveyor pulley – up to the finishing with static balancing. By utilizing the continuously updated program, fast and precision analysis of customer's specifications and requirements is easily achieved to provide precisely engineered pulley for each customer project.

We do the engineering analysis for the shaft and profiled end disc by Computerized matrix analysis to achieve accuracy for Stress and Stiffness at critical points of pulley assembly. Datasheet is attached for the computerized data references.

### LINTECH PULLEY DESIGN APPLICATION

For any customer's conveyor pulley application requirement, start from Medium Duty, Heavy Duty or even for Extra Heavy Duty, LinteCh have the capability to manufacture precisely – incorporating Ring Feder keyless RFN7015 series locking assembly. To remind you, the Ring Feder Locking has a benefit by avoiding concentrating load at the shaft due to any key machining on the shaft and any regular device of locking element (Taper or QD lock). By using this KEYLESS type joint, the emergency fracture/break on the shaft and regular locking element are avoided.

#### INDONESIA –SURABAYA

##### HEAD OFFICE:

Graha LinteCh – Wirajatim Industrial Estate- Karang Pilang Surabaya

Fax: 62-31-7664604

Phone: 62-31-7666891

Homepage: [www.LinteCh.co.id](http://www.LinteCh.co.id)

Email: [LDPTECH@INDOSAT.NET.ID](mailto:LDPTECH@INDOSAT.NET.ID)

#### FACTORY OFFICE AND PLANT:

MASTRIP70 - KARANGPILANG

WIRA JATIM INDUSTRIAL ESTATE

Fax: 62-31-7664604

Phone: 62-31-7667973

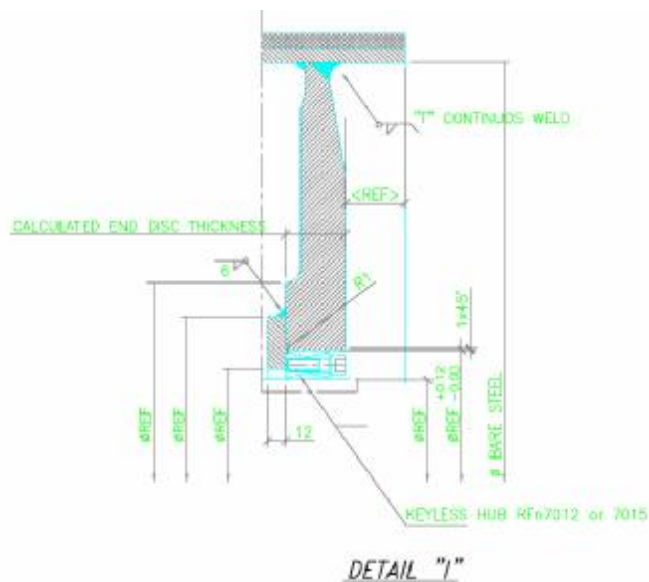
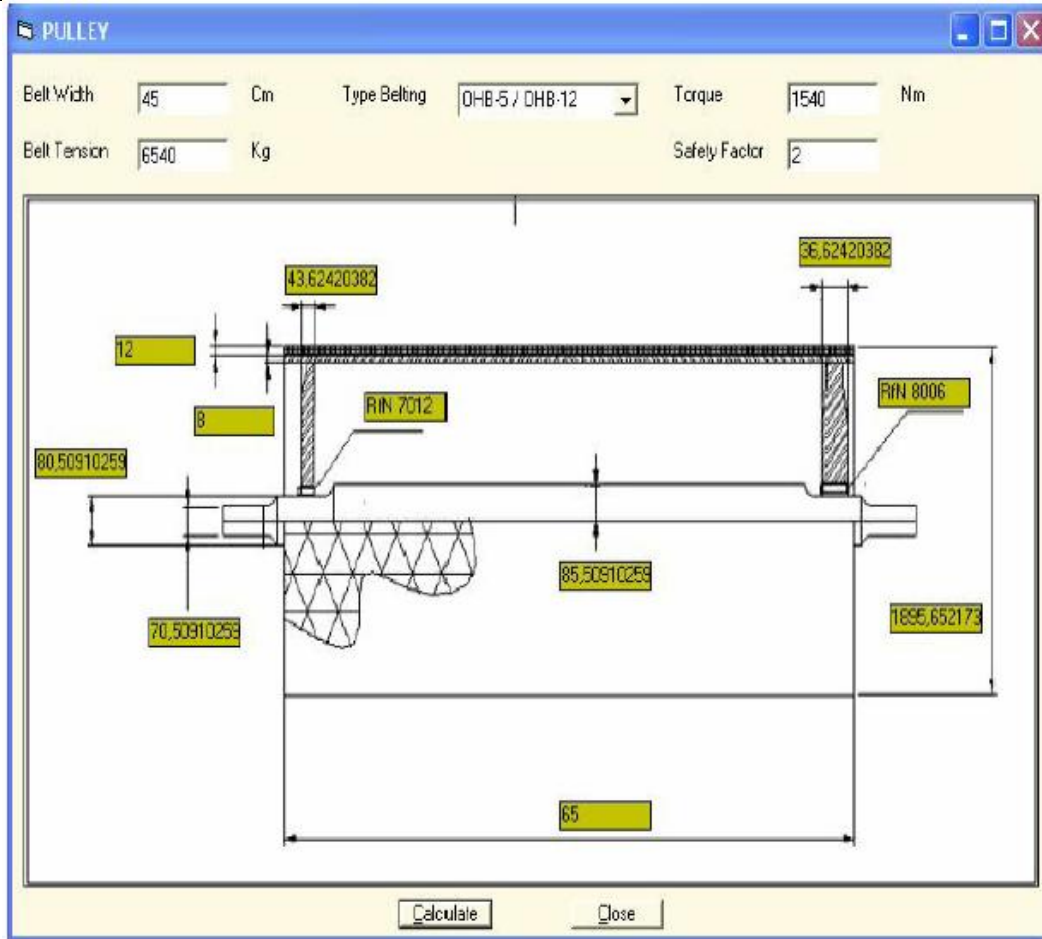

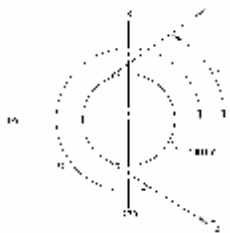

| LINTECH PULLEY DATA SHEET |              |                       |         |              |         |          |   |
|---------------------------|--------------|-----------------------|---------|--------------|---------|----------|---|
| CLIENT                    |              |                       |         |              |         | SHEET OF |   |
| PROJECT;                  |              |                       |         |              |         |          |   |
| CONVEYOR I.D              |              |                       |         | PREPARED BY: |         |          |   |
|                           |              |                       |         |              |         |          |   |
| PULLEY DATA               | TYPICAL UNIT | PULLEY IDENTIFICATION |         |              |         |          |   |
|                           |              | HEAD(1)               | TAIL(2) | SNUB(3)      | BEND(4) | GTU(5)   |   |
| <b>BELT</b>               |              |                       |         |              |         |          |   |
| 1. T1 START               | kN           |                       |         |              |         |          |  |
| ANGLE TO T1               | Deg          |                       |         |              |         |          |   |
| T2 START                  | kN           |                       |         |              |         |          |   |
| ANGLE TO T2               | Deg          |                       |         |              |         |          |   |
| 2. T1 RUN                 | kN           |                       |         |              |         |          |   |
| ANGLE TO T1               | Deg          |                       |         |              |         |          |   |
| T2 RUN                    | kN           |                       |         |              |         |          |   |
| ANGLE TO T2               | Deg          |                       |         |              |         |          |   |
| 3. WRAP ANGLE             | Deg          |                       |         |              |         |          |   |
| BELT WIDTH                | mm           |                       |         |              |         |          |   |
| BELT SPEED                | m/s          |                       |         |              |         |          |   |
| <b>SHELL</b>              |              |                       |         |              |         |          |   |
| 5. FACE WIDTH             | mm           |                       |         |              |         |          |   |
| 6. DIAMETER               | mm           |                       |         |              |         |          |   |
| 7. CROWNING               |              |                       |         |              |         |          |   |
| <b>SHAFT</b>              |              |                       |         |              |         |          |   |
| 8. BEARING CENTRES        | mm           |                       |         |              |         |          |   |
| 9. PULLEY DRIVE TYPE      |              |                       |         |              |         |          |   |
| 10. DRIVE EXT. DIAM.      | mm           |                       |         |              |         |          |   |
| 11. DRIVE EXT. TH.        | mm           |                       |         |              |         |          |   |
| 12. OVERHUNG LOAD         | kN           |                       |         |              |         |          |   |
| 13. MATERIAL              |              |                       |         |              |         |          |   |
| 14. LEVER ARM             | mm           |                       |         |              |         |          |   |
| <b>BEARING</b>            |              |                       |         |              |         |          |   |
| 15. LIFE (1000'S Hrs)     |              |                       |         |              |         |          |   |
| 16. SEAL TYPE             |              |                       |         |              |         |          |   |
| <b>MOTOR</b>              |              |                       |         |              |         |          |   |
| 17. 100% POWER            | kW           |                       |         |              |         |          |   |
| 18. START FACTOR          |              |                       |         |              |         |          |   |
| <b>LAGGING</b>            |              |                       |         |              |         |          |   |
| THICKNESS                 | mm           |                       |         |              |         |          |   |
| 19. MATERIAL              |              |                       |         |              |         |          |   |
| 20. PATTERN               |              |                       |         |              |         |          |   |
| QUANTITY                  |              |                       |         |              |         |          |   |





**LINTECH PULLEY HD****HEAVY DUTY DRUM PULLEY ASSEMBLIES**

**LINTECH** is one of largest Indonesian company who specializing in design and manufacturing conveyor pulley. A solid R & D department produces the best design and manufacturing technique to meet the most advanced pulley in the market.

**LINTECH PULLEY** is available in standard range or made to order based upon conveyor load, belt tension, belt wrap angles and bearing centers, supplied for belt ratings up to and exceeding 8,000 PIW (Pounds per Inch of Belt Width) or 1,400 kN/m.

**FEATURE**

- ▮ **THE PULLEY DESIGN** – all Lintech's pulley stress and tension analysis is product of computational process of Lintech engineering software. Shell, profiled end disc and shaft stress are under finite element analysis methode.
- ▮ **THE PULLEY ASSEMBLY** - Welded, integral unit and "T" Section Super hub versions that minimize the deleterious effects of welding heat affected zones. Pre grooved ends shell and profiled end discs fully welded (Ultrasound tested) and connect to continuos shaft using Keyless locking device to avoid concentrating stress on shaft. Full 360 degree fillet welding of internal support discs when used. The complete assembly mounted on assigned bearing and housing size and packed with custom steel skid for transport safely purpose.
- ▮ **THE SHELL** – the material is selected from high quality - certified steel plate and rolled to cylindrical required diameter – vee shaped continuous weld seam and grooved at both end for precision mounting of end disc. The shell surface is center crowned or straight faced. Turned rim outside diameters to .015 TIR, post weld thermal stress relieving, static balancing to ISO Standard 1940/1-1986 (Grade G-40), dynamic balancing, magnetic particle and ultra sound weld testing, and line boring of end disc inside diameters.



**LINTECH PULLEY HD****HEAVY DUTY DRUM PULLEY ASSEMBLIES**

- | **THE LOCKING ELEMENT ASSEMBLY** – Keyless locking assembly – which is Ringfeder – Germany imported devices, a famous shrink fit device for quick mounting and dismounting – effective for maintenance issue.
- | **THE SHAFT** – Shafts material and size are under Lintech standard design calculation for stress, bending and torsion. Minimum stress production is maintained in machining process for fine surface at precision tolerance radius to prevent failure and warranty long life service.
- | **THE BEARING AND HOUSING** – A quality bearings and housings are mounted to pulley assembly with adapter sleeve and spacing ring. All adapter sleeves are tightened to get standard required bearing tolerances.
- | **THE LAGGING** - Various proven and certified **Lintech** hot or cold bonding rubber lagging materials are available from DURO45, 60 and 70 – Natural and Synthetic rubber for longest wear life – plain face or grooved surface to suit any requirements.
- | **THE PACKING AND TAG** – Steel skid is provided for secure transport, loading/unloading. Permanently fastened metal tags with unique identification numbers and date of manufacture are provided. Certified, reproducible drawings are available on request.

**APPLICATION**

- | Mining
  - | Transportation
  - | Power Plants
  - | Pulp and Paper
- Waste and Foundries: Head, snub, bend and take-up pulleys on bulk belt conveyors used in mining, stone, clay, glass, cement, coal mining and preparation plants, coal fired electric generating plants, transportation ports & terminals, woodchip making, solid waste, concrete and wood recycling plants, iron and steel mills, and iron foundries.

**PLEASE CONTACT LINTECH OFFICER FOR FURTHER ASSISTANCE**

# Locking Assemblies RINGFEDER®

## RfN 7012

Supplement 1 to catalogue RfN 7012

Functional values concerning  
maximum admissible  
tightening torque per screw



| Locking Assembly dimensions |     |         |                | Transmissible |                             | Surface pressure                |     | Locking screws DIN 912-12.9 |           |      |                | Weight               |                |    |
|-----------------------------|-----|---------|----------------|---------------|-----------------------------|---------------------------------|-----|-----------------------------|-----------|------|----------------|----------------------|----------------|----|
| d x D<br>mm                 | L   | I<br>mm | L <sub>1</sub> | T<br>Nm       | or<br>F <sub>ax</sub><br>kN | between Locking<br>Assembly and |     | Thread                      |           | Qty. | d <sub>G</sub> | T <sub>A</sub><br>Nm | d <sub>D</sub> | kg |
|                             |     |         |                |               |                             | shaft                           | hub | p                           | p'        |      |                |                      |                |    |
| 19 x 47                     | 20  | 17      | 27,5           | 310           | 32                          | 268                             | 110 | 8                           | M 6 x 18  | 17   | M 8            | 0,24                 |                |    |
| 20 x 47                     | 20  | 17      | 27,5           | 320           | 32                          | 255                             | 110 | 8                           | M 6 x 18  | 17   | M 8            | 0,24                 |                |    |
| 22 x 47                     | 20  | 17      | 27,5           | 360           | 32                          | 237                             | 110 | 8                           | M 6 x 18  | 17   | M 8            | 0,23                 |                |    |
| 24 x 50                     | 20  | 17      | 27,5           | 430           | 36                          | 237                             | 116 | 9                           | M 6 x 18  | 17   | M 8            | 0,26                 |                |    |
| 25 x 50                     | 20  | 17      | 27,5           | 460           | 36                          | 230                             | 116 | 9                           | M 6 x 18  | 17   | M 8            | 0,25                 |                |    |
| 28 x 55                     | 20  | 17      | 27,5           | 570           | 40                          | 225                             | 116 | 9                           | M 6 x 18  | 17   | M 8            | 0,3                  |                |    |
| 30 x 55                     | 20  | 17      | 27,5           | 600           | 40                          | 212                             | 116 | 9                           | M 6 x 18  | 17   | M 8            | 0,29                 |                |    |
| 32 x 60                     | 20  | 17      | 27,5           | 760           | 48                          | 233                             | 128 | 12                          | M 6 x 18  | 17   | M 8            | 0,34                 |                |    |
| 35 x 60                     | 20  | 17      | 27,5           | 850           | 48                          | 219                             | 128 | 12                          | M 6 x 18  | 17   | M 8            | 0,32                 |                |    |
| 38 x 65                     | 20  | 17      | 27,5           | 1050          | 55                          | 228                             | 134 | 15                          | M 6 x 18  | 17   | M 8            | 0,36                 |                |    |
| 40 x 65                     | 20  | 17      | 27,5           | 1110          | 55                          | 219                             | 134 | 15                          | M 6 x 18  | 17   | M 8            | 0,34                 |                |    |
| 42 x 75                     | 24  | 20      | 33,5           | 1750          | 84                          | 265                             | 147 | 12                          | M 8 x 22  | 41   | M 10           | 0,6                  |                |    |
| 45 x 75                     | 24  | 20      | 33,5           | 1880          | 84                          | 246                             | 147 | 12                          | M 8 x 22  | 41   | M 10           | 0,57                 |                |    |
| 48 x 80                     | 24  | 20      | 33,5           | 1990          | 83                          | 230                             | 135 | 12                          | M 8 x 22  | 41   | M 10           | 0,62                 |                |    |
| 50 x 80                     | 24  | 20      | 33,5           | 2070          | 83                          | 223                             | 135 | 12                          | M 8 x 22  | 41   | M 10           | 0,6                  |                |    |
| 55 x 85                     | 24  | 20      | 33,5           | 2650          | 97                          | 234                             | 152 | 14                          | M 8 x 22  | 41   | M 10           | 0,63                 |                |    |
| 60 x 90                     | 24  | 20      | 33,5           | 2890          | 97                          | 210                             | 140 | 14                          | M 8 x 22  | 41   | M 10           | 0,69                 |                |    |
| 65 x 95                     | 24  | 20      | 33,5           | 3560          | 109                         | 223                             | 152 | 16                          | M 8 x 22  | 41   | M 10           | 0,73                 |                |    |
| 70 x 110                    | 28  | 24      | 39,5           | 5450          | 156                         | 249                             | 154 | 14                          | M 10 x 25 | 83   | M 12           | 1,26                 |                |    |
| 75 x 115                    | 28  | 24      | 39,5           | 5810          | 155                         | 231                             | 148 | 14                          | M 10 x 25 | 83   | M 12           | 1,33                 |                |    |
| 80 x 120                    | 28  | 24      | 39,5           | 6160          | 155                         | 213                             | 142 | 14                          | M 10 x 25 | 83   | M 12           | 1,4                  |                |    |
| 85 x 125                    | 28  | 24      | 39,5           | 7450          | 175                         | 231                             | 154 | 16                          | M 10 x 25 | 83   | M 12           | 1,49                 |                |    |
| 90 x 130                    | 28  | 24      | 39,5           | 7820          | 174                         | 213                             | 148 | 16                          | M 10 x 25 | 83   | M 12           | 1,53                 |                |    |
| 95 x 135                    | 28  | 24      | 39,5           | 9360          | 198                         | 231                             | 160 | 18                          | M 10 x 25 | 83   | M 12           | 1,62                 |                |    |
| 100 x 145                   | 33  | 26      | 47             | 11100         | 223                         | 226                             | 157 | 14                          | M 12 x 30 | 145  | M 14           | 2,01                 |                |    |
| 110 x 155                   | 33  | 26      | 47             | 12180         | 221                         | 209                             | 145 | 14                          | M 12 x 30 | 145  | M 14           | 2,15                 |                |    |
| 120 x 165                   | 33  | 26      | 47             | 15200         | 263                         | 215                             | 157 | 16                          | M 12 x 30 | 145  | M 14           | 2,35                 |                |    |
| 130 x 180                   | 38  | 34      | 52             | 20400         | 315                         | 191                             | 133 | 20                          | M 12 x 35 | 145  | M 14           | 3,51                 |                |    |
| 140 x 190                   | 38  | 34      | 52             | 24200         | 345                         | 191                             | 145 | 22                          | M 12 x 35 | 145  | M 14           | 3,85                 |                |    |
| 150 x 200                   | 38  | 34      | 52             | 28000         | 376                         | 197                             | 145 | 24                          | M 12 x 35 | 145  | M 14           | 4,07                 |                |    |
| 160 x 210                   | 38  | 34      | 52             | 32500         | 406                         | 197                             | 151 | 26                          | M 12 x 35 | 145  | M 14           | 4,3                  |                |    |
| 170 x 225                   | 44  | 38      | 60             | 39700         | 467                         | 194                             | 145 | 22                          | M 14 x 40 | 230  | M 16           | 5,78                 |                |    |
| 180 x 235                   | 44  | 38      | 60             | 45700         | 508                         | 200                             | 151 | 24                          | M 14 x 40 | 230  | M 16           | 6,05                 |                |    |
| 190 x 250                   | 52  | 46      | 68             | 56300         | 593                         | 182                             | 139 | 28                          | M 14 x 45 | 230  | M 16           | 8,25                 |                |    |
| 200 x 260                   | 52  | 46      | 68             | 63500         | 635                         | 182                             | 139 | 30                          | M 14 x 45 | 230  | M 16           | 8,65                 |                |    |
| 220 x 285                   | 56  | 50      | 74             | 81800         | 746                         | 181                             | 138 | 26                          | M 16 x 50 | 355  | M 20           | 11,22                |                |    |
| 240 x 305                   | 56  | 50      | 74             | 102900        | 860                         | 193                             | 150 | 30                          | M 16 x 50 | 355  | M 20           | 12,2                 |                |    |
| 260 x 325                   | 56  | 50      | 74             | 125000        | 962                         | 199                             | 156 | 34                          | M 16 x 50 | 355  | M 20           | 13,2                 |                |    |
| 280 x 355                   | 66  | 60      | 86,5           | 153000        | 1095                        | 174                             | 138 | 32                          | M 18 x 60 | 485  | M 22           | 19,2                 |                |    |
| 300 x 375                   | 66  | 60      | 86,5           | 183000        | 1221                        | 180                             | 144 | 36                          | M 18 x 60 | 485  | M 22           | 20,5                 |                |    |
| 320 x 405                   | 78  | 72      | 100,5          | 250000        | 1558                        | 178                             | 143 | 36                          | M 20 x 70 | 690  | M 24           | 29,6                 |                |    |
| 340 x 425                   | 78  | 72      | 100,5          | 266500        | 1558                        | 172                             | 137 | 36                          | M 20 x 70 | 690  | M 24           | 31,1                 |                |    |
| 360 x 455                   | 90  | 84      | 116            | 350500        | 1943                        | 173                             | 137 | 36                          | M 22 x 80 | 930  | M 27           | 42,2                 |                |    |
| 380 x 475                   | 90  | 84      | 116            | 367000        | 1931                        | 161                             | 131 | 36                          | M 22 x 80 | 930  | M 27           | 44                   |                |    |
| 400 x 495                   | 90  | 84      | 116            | 384000        | 1920                        | 155                             | 125 | 36                          | M 22 x 80 | 930  | M 27           | 46                   |                |    |
| 420 x 515                   | 90  | 84      | 116            | 446000        | 2122                        | 161                             | 131 | 40                          | M 22 x 80 | 930  | M 27           | 50                   |                |    |
| 440 x 545                   | 102 | 96      | 130            | 545000        | 2470                        | 155                             | 126 | 40                          | M 24 x 90 | 1200 | M 30           | 64,6                 |                |    |
| 460 x 565                   | 102 | 96      | 130            | 565000        | 2450                        | 150                             | 120 | 40                          | M 24 x 90 | 1200 | M 30           | 67,4                 |                |    |
| 480 x 585                   | 102 | 96      | 130            | 620000        | 2580                        | 150                             | 120 | 42                          | M 24 x 90 | 1200 | M 30           | 71                   |                |    |
| 500 x 605                   | 102 | 96      | 130            | 670000        | 2680                        | 150                             | 120 | 44                          | M 24 x 90 | 1200 | M 30           | 72,6                 |                |    |

# Locking Assemblies RINGFEDER® RfN 7012

Required hub outside diameter  $D_N$  when using **one** RfN 7012 Locking Assembly depending on the yield point of the hub material

The values in the table for  $D_N$  apply to the use of **one** RfN 7012 Locking Assembly

Width of the hub  $B \geq 2 l$   
Depth of the bore  $b \approx L_1$

Hub section unweakened (See back page)

Cast hubs should be of perfect quality (flawless).

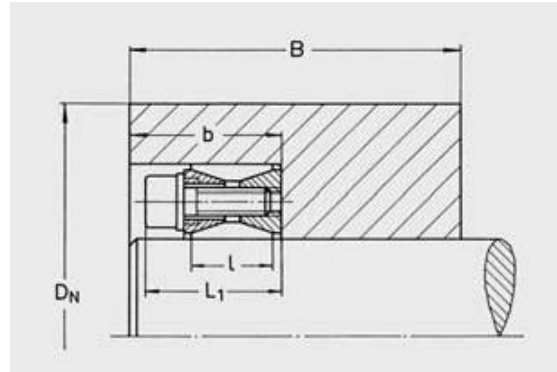

| RfN 7012    |             | Required min. hub outside diameter $D_N$ (mm) for: |     |     |     |     |     |     |     |     |
|-------------|-------------|--|-----|-----|-----|-----|-----|-----|-----|-----|
| d x D<br>mm | $T_A$<br>Nm | yield point $R_{p0,2N}$ (N/mm <sup>2</sup> )       |     |     |     |     |     |     |     |     |
|             |             | 150  | 180 | 200 | 220 | 250 | 270 | 300 | 350 | 400 |
| 19 x 47     | 17          | 76   | 70  | 68  | 65  | 62  | 62  | 60  | 58  | 56  |
| 20 x 47     | 17          | 76   | 70  | 68  | 65  | 62  | 62  | 60  | 58  | 56  |
| 22 x 47     | 17          | 76   | 70  | 68  | 65  | 62  | 62  | 60  | 58  | 56  |
| 24 x 50     | 17          | 84   | 75  | 72  | 70  | 68  | 65  | 64  | 62  | 60  |
| 25 x 50     | 17          | 84   | 75  | 72  | 70  | 68  | 65  | 64  | 62  | 60  |
| 28 x 55     | 17          | 92   | 84  | 80  | 78  | 74  | 72  | 70  | 68  | 66  |
| 30 x 55     | 17          | 92   | 84  | 80  | 78  | 74  | 72  | 70  | 68  | 66  |
| 32 x 60     | 17          | 106  | 95  | 90  | 88  | 84  | 82  | 78  | 75  | 74  |
| 35 x 60     | 17          | 106  | 95  | 90  | 88  | 84  | 82  | 78  | 75  | 74  |
| 38 x 65     | 17          | 120  | 106 | 100 | 96  | 92  | 90  | 86  | 82  | 80  |
| 40 x 65     | 17          | 120  | 106 | 100 | 96  | 92  | 90  | 86  | 82  | 80  |
| 42 x 75     | 41          | 148  | 130 | 122 | 115 | 110 | 105 | 102 | 98  | 95  |
| 45 x 75     | 41          | 148  | 130 | 122 | 115 | 110 | 105 | 102 | 98  | 95  |
| 48 x 80     | 41          | 148  | 130 | 124 | 118 | 112 | 110 | 106 | 102 | 100 |
| 50 x 80     | 41          | 148  | 130 | 124 | 118 | 112 | 110 | 106 | 102 | 100 |
| 55 x 85     | 41          | —  | 150 | 140 | 132 | 125 | 122 | 118 | 112 | 108 |
| 60 x 90     | 41          | 170  | 150 | 142 | 135 | 128 | 124 | 120 | 116 | 112 |
| 65 x 95     | 41          | —  | 168 | 156 | 148 | 140 | 135 | 132 | 125 | 120 |
| 70 x 110    | 83          | —  | 195 | 182 | 172 | 162 | 158 | 152 | 145 | 140 |
| 75 x 115    | 83          | 228  | 198 | 186 | 176 | 168 | 164 | 158 | 150 | 144 |
| 80 x 120    | 83          | 230  | 202 | 190 | 182 | 172 | 168 | 162 | 155 | 150 |
| 85 x 125    | 83          | —  | 220 | 208 | 195 | 185 | 180 | 172 | 165 | 158 |
| 90 x 130    | 83          | 258  | 225 | 210 | 200 | 190 | 185 | 178 | 170 | 165 |
| 95 x 135    | 83          | —  | 245 | 230 | 218 | 205 | 198 | 188 | 180 | 175 |
| 100 x 145   | 145         | —  | 260 | 245 | 230 | 212 | 210 | 202 | 192 | 185 |
| 110 x 155   | 145         | 305  | 265 | 248 | 238 | 225 | 220 | 210 | 200 | 195 |
| 120 x 165   | 145         | —  | 298 | 278 | 262 | 248 | 238 | 230 | 220 | 210 |
| 130 x 180   | 145         | 328  | 290 | 278 | 265 | 252 | 245 | 238 | 228 | 222 |
| 140 x 190   | 145         | 370  | 325 | 305 | 290 | 275 | 268 | 258 | 248 | 238 |
| 150 x 200   | 145         | 390  | 340 | 320 | 305 | 290 | 280 | 270 | 260 | 250 |
| 160 x 210   | 145         | —  | 368 | 345 | 328 | 308 | 300 | 290 | 275 | 265 |
| 170 x 225   | 230         | 438  | 382 | 358 | 345 | 325 | 315 | 305 | 292 | 282 |
| 180 x 235   | 230         | —  | 410 | 385 | 365 | 345 | 335 | 325 | 308 | 300 |
| 190 x 250   | 230         | 468  | 415 | 390 | 375 | 355 | 345 | 335 | 320 | 310 |
| 200 x 260   | 230         | 488  | 430 | 408 | 388 | 370 | 360 | 348 | 335 | 325 |
| 220 x 285   | 355         | 532  | 472 | 445 | 425 | 402 | 392 | 380 | 365 | 355 |
| 240 x 305   | 355         | —  | 528 | 495 | 470 | 448 | 430 | 415 | 398 | 385 |
| 260 x 325   | 355         | —  | 580 | 540 | 515 | 482 | 470 | 450 | 430 | 415 |
| 280 x 355   | 485         | 662  | 588 | 552 | 530 | 502 | 488 | 475 | 455 | 442 |
| 300 x 375   | 485         | 725  | 635 | 600 | 570 | 540 | 525 | 508 | 485 | 470 |
| 320 x 405   | 690         | 780  | 682 | 640 | 615 | 580 | 565 | 545 | 525 | 508 |
| 340 x 425   | 690         | 790  | 700 | 660 | 630 | 600 | 585 | 562 | 540 | 525 |
| 360 x 455   | 930         | 845  | 748 | 708 | 675 | 642 | 625 | 602 | 580 | 560 |
| 380 x 475   | 930         | 852  | 760 | 720 | 690 | 658 | 645 | 625 | 600 | 580 |
| 400 x 495   | 930         | 858  | 775 | 735 | 710 | 675 | 660 | 640 | 615 | 600 |
| 420 x 515   | 930         | 925  | 826 | 780 | 750 | 715 | 700 | 675 | 650 | 630 |
| 440 x 545   | 1200        | 950  | 852 | 815 | 780 | 742 | 725 | 705 | 678 | 660 |
| 460 x 565   | 1200        | 955  | 865 | 825 | 800 | 765 | 742 | 725 | 695 | 680 |
| 480 x 585   | 1200        | 990  | 896 | 855 | 825 | 790 | 768 | 750 | 720 | 705 |
| 500 x 605   | 1200        | 1025   | 928 | 885 | 855 | 820 | 795 | 775 | 745 | 728 |

# Locking Assemblies RINGFEDER® RfN 7012

*Required hub outside diameter  $D_N$  when using **two** RfN 7012 Locking Assemblies depending on the yield point of the hub material*

The values in the table for  $D_N$  apply to the use of **two** or more RfN 7012 Locking Assemblies

Width of the hub  $B \geq L_1 \times (1 + n)$ ,  
 $n$  = number of Locking Assemblies used

Hub section unweakened (See back page)

Cast hubs should be of perfect quality (flawless).

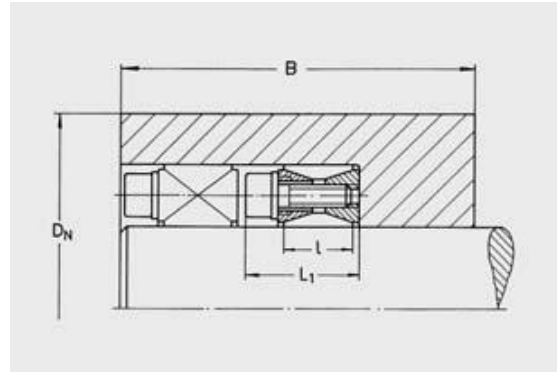

| RfN 7012    |             | Required min. hub outside diameter $D_N$ (mm) for: |      |      |     |     |     |     |     |     |
|-------------|-------------|--|------|------|-----|-----|-----|-----|-----|-----|
| d x D<br>mm | $T_A$<br>Nm | yield point $R_{p0,2N}$ ( N/mm <sup>2</sup> )      |      |      |     |     |     |     |     |     |
|             |             | 150  | 180  | 200  | 220 | 250 | 270 | 300 | 350 | 400 |
| 19 x 47     | 17          | 94   | 82   | 76   | 72  | 68  | 66  | 64  | 62  | 60  |
| 20 x 47     | 17          | 94   | 82   | 76   | 72  | 68  | 66  | 64  | 62  | 60  |
| 22 x 47     | 17          | 94   | 82   | 76   | 72  | 68  | 66  | 64  | 62  | 60  |
| 24 x 50     | 17          | 105  | 90   | 85   | 80  | 75  | 72  | 70  | 66  | 64  |
| 25 x 50     | 17          | 105  | 90   | 85   | 80  | 75  | 72  | 70  | 66  | 64  |
| 28 x 55     | 17          | 115  | 98   | 92   | 88  | 82  | 80  | 76  | 74  | 70  |
| 30 x 55     | 17          | 115  | 98   | 92   | 88  | 82  | 80  | 76  | 74  | 70  |
| 32 x 60     | 17          | 138  | 115  | 106  | 100 | 95  | 90  | 86  | 82  | 78  |
| 35 x 60     | 17          | 138  | 115  | 106  | 100 | 95  | 90  | 86  | 82  | 78  |
| 38 x 65     | 17          | 160  | 130  | 120  | 112 | 104 | 100 | 95  | 90  | 86  |
| 40 x 65     | 17          | 160  | 130  | 120  | 112 | 104 | 100 | 95  | 90  | 86  |
| 42 x 75     | 41          | —  | 165  | 148  | 139 | 126 | 120 | 115 | 108 | 102 |
| 45 x 75     | 41          | —  | 165  | 148  | 139 | 126 | 120 | 115 | 108 | 102 |
| 48 x 80     | 41          | 200  | 160  | 148  | 138 | 128 | 124 | 118 | 112 | 108 |
| 50 x 80     | 41          | 200  | 160  | 148  | 138 | 128 | 124 | 118 | 112 | 108 |
| 55 x 85     | 41          | —  | 195  | 175  | 160 | 145 | 138 | 132 | 125 | 118 |
| 60 x 90     | 41          | —  | 188  | 170  | 160 | 148 | 140 | 135 | 126 | 120 |
| 65 x 95     | 41          | —  | 218  | 195  | 178 | 162 | 155 | 148 | 138 | 132 |
| 70 x 110    | 83          | —  | 255  | 228  | 208 | 190 | 182 | 172 | 160 | 152 |
| 75 x 115    | 83          | —  | 255  | 230  | 212 | 194 | 185 | 175 | 165 | 158 |
| 80 x 120    | 83          | —  | 255  | 230  | 214 | 198 | 190 | 180 | 170 | 162 |
| 85 x 125    | 83          | —  | 290  | 258  | 236 | 216 | 206 | 195 | 182 | 172 |
| 90 x 130    | 83          | —  | 288  | 258  | 238 | 218 | 208 | 198 | 185 | 178 |
| 95 x 135    | 83          | —  | 330  | 288  | 262 | 238 | 228 | 215 | 200 | 188 |
| 100 x 145   | 145         | —  | 345  | 305  | 278 | 254 | 242 | 228 | 212 | 202 |
| 110 x 155   | 145         | —  | 336  | 302  | 280 | 258 | 245 | 235 | 220 | 210 |
| 120 x 165   | 145         | —  | 392  | 345  | 318 | 288 | 275 | 258 | 242 | 228 |
| 130 x 180   | 145         | 440  | 358  | 328  | 308 | 285 | 275 | 262 | 248 | 238 |
| 140 x 190   | 145         | —  | 410  | 370  | 342 | 315 | 302 | 288 | 270 | 258 |
| 150 x 200   | 145         | —  | 432  | 390  | 360 | 330 | 318 | 300 | 285 | 270 |
| 160 x 210   | 145         | —  | 475  | 425  | 390 | 355 | 342 | 322 | 302 | 288 |
| 170 x 225   | 230         | —  | 485  | 438  | 405 | 372 | 356 | 338 | 318 | 305 |
| 180 x 235   | 230         | —  | 530  | 475  | 435 | 398 | 382 | 360 | 338 | 322 |
| 190 x 250   | 230         | —  | 515  | 468  | 438 | 405 | 388 | 370 | 348 | 335 |
| 200 x 260   | 230         | —  | 538  | 488  | 455 | 420 | 405 | 385 | 362 | 348 |
| 220 x 285   | 355         | —  | 582  | 532  | 498 | 460 | 440 | 420 | 400 | 380 |
| 240 x 305   | 355         | —  | 685  | 610  | 562 | 518 | 492 | 468 | 438 | 415 |
| 260 x 325   | 355         | —  | 765  | 678  | 620 | 565 | 540 | 510 | 472 | 450 |
| 280 x 355   | 485         | —  | 725  | 662  | 620 | 572 | 548 | 525 | 495 | 475 |
| 300 x 375   | 485         | —  | 800  | 725  | 672 | 620 | 595 | 565 | 530 | 508 |
| 320 x 405   | 690         | —  | 860  | 780  | 722 | 665 | 638 | 605 | 570 | 545 |
| 340 x 425   | 690         | —  | 865  | 788  | 738 | 682 | 655 | 625 | 588 | 568 |
| 360 x 455   | 930         | —  | 925  | 845  | 790 | 730 | 702 | 670 | 630 | 608 |
| 380 x 475   | 930         | 1130   | 930  | 855  | 800 | 745 | 720 | 685 | 648 | 625 |
| 400 x 495   | 930         | 1110   | 928  | 858  | 810 | 760 | 735 | 700 | 665 | 640 |
| 420 x 515   | 930         | 1225   | 1005 | 925  | 868 | 805 | 780 | 745 | 705 | 675 |
| 440 x 545   | 1200        | 1235   | 1025 | 950  | 895 | 835 | 810 | 770 | 732 | 705 |
| 460 x 565   | 1200        | 1205   | 1025 | 955  | 905 | 850 | 820 | 788 | 755 | 730 |
| 480 x 585   | 1200        | 1250   | 1060 | 990  | 940 | 880 | 850 | 815 | 780 | 750 |
| 500 x 605   | 1200        | 1290   | 1100 | 1025 | 970 | 910 | 880 | 842 | 805 | 775 |

# Locking Assemblies RINGFEDER® RfN 7012

## Calculations

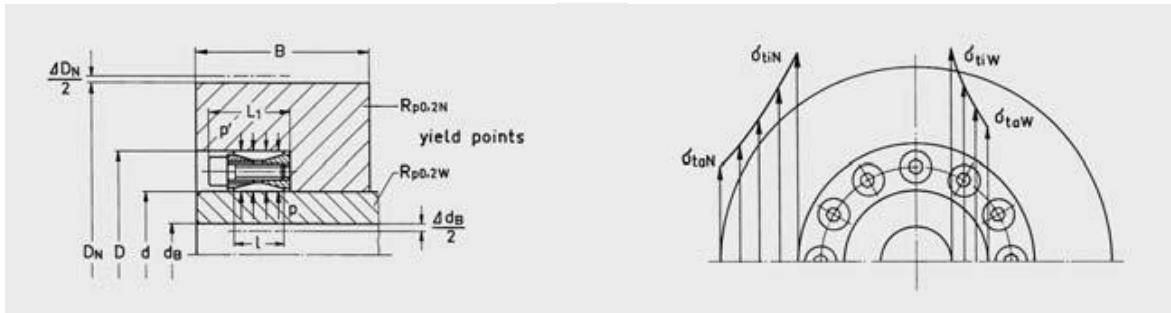

Equations for thick-walled cylinders give good service in the estimation of the tangential (tension) stresses occurring in the hub and hollow shaft. Exact determination of the true stresses and deformations (expanding, contraction) is very difficult in view of the wide scatter of the coefficients of friction and be-

cause of the differing hub and hollow shaft configurations. Constructions in which Locking Assemblies are intended to be arranged under or above bearings should therefore be avoided as far as possible, or be more closely investigated (e. g. test clamping).

### Hub calculation

- 1)  $p' \approx p \times \frac{d}{D}$
- 2)  $a_N = \frac{D_N}{D}$
- 3)  $\sigma_{tiN} = \frac{p'(a_N^2 + 1)}{a_N^2 - 1} ; B = l$
- 4)  $\sigma_{taN} = \frac{2 \times p'}{a_N^2 - 1} ; B = l$
- 5)  $\sigma_{tiN} = \frac{C_3 \times p'(a_N^2 + 1)}{a_N^2 - 1} ; B > 2l$
- 6)  $\sigma_{taN} = \frac{C_3 \times p' \times 2}{a_N^2 - 1} ; B > 2l$
- 7)  $D_N \cong D \times \sqrt{\frac{R_{p0,2N} + C_3 \times p'}{R_{p0,2N} - C_3 \times p'}} ; a)$
- 8)  $D_N \cong D \times \sqrt{\frac{R_{p0,2N} + C_3 \times p'}{R_{p0,2N} - C_3 \times p'}} + d_G ; b)$
- 9)  $\Delta D_N \approx \frac{D_N \times \sigma_{taN}}{E_N} ; c)$
- 10)  $p'_{adm} \approx \frac{R_{p0,2N}}{C_3} \times \frac{D_N^2 - D^2}{D_N^2 + D^2} ; a)$

a) cross section of the hub above the Locking Assembly, unweakened.

$C_3 = 0,6$  for one Locking Assembly and  $B \geq 2l$

$C_3 = 0,8$  for two or more Locking Assemblies  
 $B \geq L_1 \times (1 + n)$ ; n = number of Locking Assemblies

$C_3 = 1$  for one or more Locking Assemblies and  
 $B = l$  or  $B = L_1 \times n$

b) if bores or threads ( $d_G$ ) in the hub.

$C_3 = 0,8$  if  $B \geq 2l$  or  $B \geq L_1 \times (1 + n)$

$C_3 = 1$  if  $B = l$  or  $B = L_1 \times n$

c) approximated value. A higher scatter range is possible, as the value depends on the actual coefficient of friction and the shape of the hub.

### Hollow shaft calculation (minimum requirements)

- 1)  $a_W = \frac{d}{d_B}$
- 2)  $\sigma_{tiW} \approx 2 \times p \times C_3 \times \frac{a_W^2}{a_W^2 - 1}$
- 3)  $\sigma_{taW} \approx p \times C_3 \times \frac{a_W^2 + 1}{a_W^2 - 1}$
- 4)  $d_B \cong d \times \sqrt{\frac{R_{p0,2W} - 2 \times p \times C_3}{R_{p0,2W}}} ; a)$
- 5)  $d_B \cong d \times \sqrt{\frac{R_{p0,2W} - 2 \times p \times C_3}{R_{p0,2W}}} - d_G ; b)$
- 6)  $\Delta d_B \approx \frac{d_B \times \sigma_{tiW}}{E_W}$
- 7)  $\Delta d \approx \frac{p \times d \times (m - 1)}{E_W \times m} ; c)$
- 8)  $R_{p0,2W} > p ; c)$
- 9)  $p_{adm} \approx \frac{R_{p0,2W} \left[ 1 - \left( \frac{d_B}{d} \right)^2 \right]}{C_3 \times 2} ; a)$

a) cross section of the hollow shaft below the Locking Assembly, unweakened, and hollow shaft longer than  $2l$  (generally the case. Hollow shaft-  $2l$  are very rare).

$C_3 = 0,6$  for one Locking Assembly

$C_3 = 0,8$  for two or more Locking Assemblies

b) if bores or threads ( $d_G$ ) in the hollow shaft.

$C_3 = 0,8$

c) for solid shafts

For steel:

$E = 210000 \text{ N/mm}^2$

$m = 10/3$

### RINGFEDER GMBH

Oberschlesienstr. 15 · D-47807 Krefeld

P.O. Box 130619 · D-47758 Krefeld

Phone (02151) 835-0 · Fax (02151) 835-200/207

<http://www.ringfeder.de>



A certified company in accordance with  
 DIN EN ISO 9001